

對稱 . 旋轉 . 發現美



為什麼需要學？為了理解、珍惜即將消逝的文化記憶.....

從竹科工程師變博物館館長！ 他復刻消失百年的台灣花磚



徐嘉彬指出，新加坡、馬來西亞等地的花磚老屋都被政府立法保護，但台灣的花磚老屋卻遭到大量拆除.....

研究所畢業後，他到竹科的科技廠工作，有了穩定收入之後，更開始展開收購、保存花磚的行動。

目前「台灣花磚有限公司」出產的復刻花磚，不但成功打入國內建材市場，還外銷到日本。重返台灣的英商巴克萊銀行，指定要用台灣花磚；日本SPA WORLD溫泉浴場，為了重現日本大正及昭和年代外銷各國的花磚，也購買了5000多片台灣花磚，打造出獨一無二的復古空間。



徐嘉彬說，台灣90%的花磚是在屋簷上，因為那是房子最顯眼的地方，可以讓外人看到這戶人家的富貴與品味。

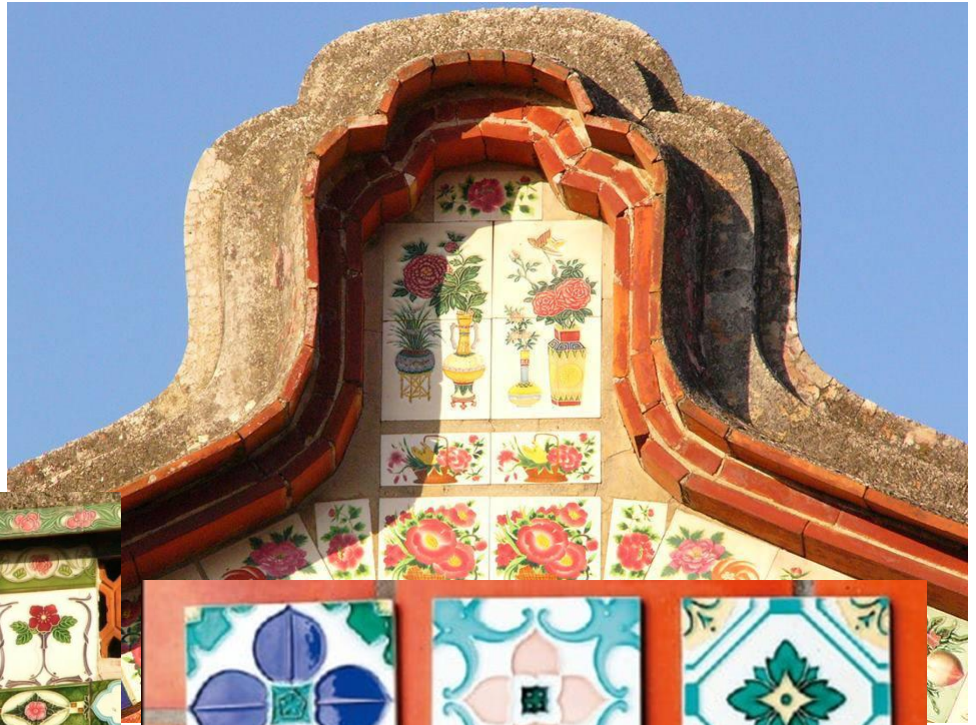

黃宅老屋拍攝 by Steve Dan

1915 問世

1935 停產。

「台灣花磚，僅在這塊土地出現二十年。」



當時顯赫一時的富貴人家屋宅上，就會看到這些從日本進口而來的「馬約利卡磁磚」(Majolica Tiles)，匠師手工製作相當精緻費工，每片花磚圖騰代表著一種祝福，如蘋果代表平安、石榴代表多子多孫、蝙蝠代表福氣、桃子代表長壽。

一片花磚比相同土地面積的售價還高，隨著二次世界大戰爆發後停產，從此這些美麗花磚便凝結在老厝屋脊上，漸漸地蒙塵，被世人遺忘。



基本圖案

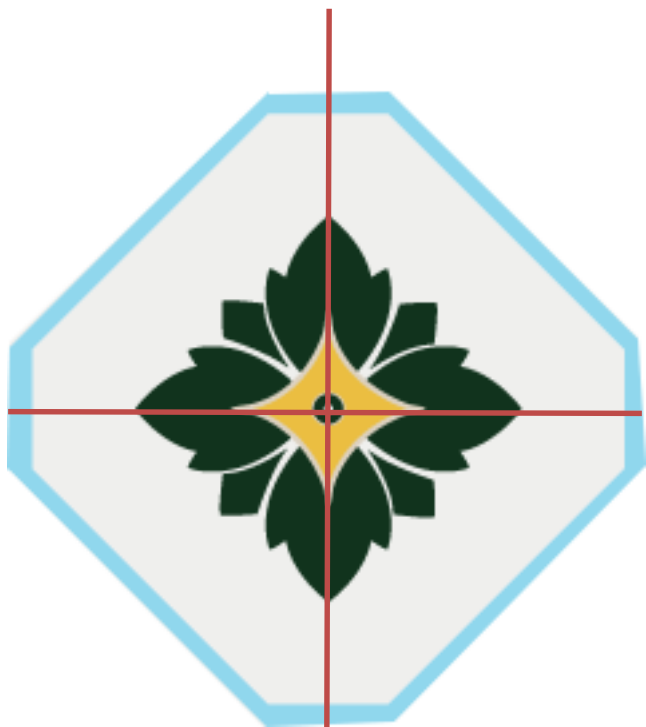
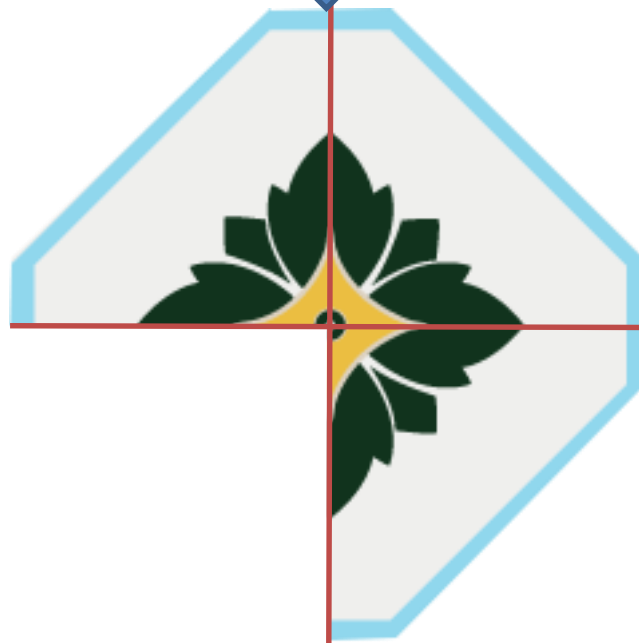
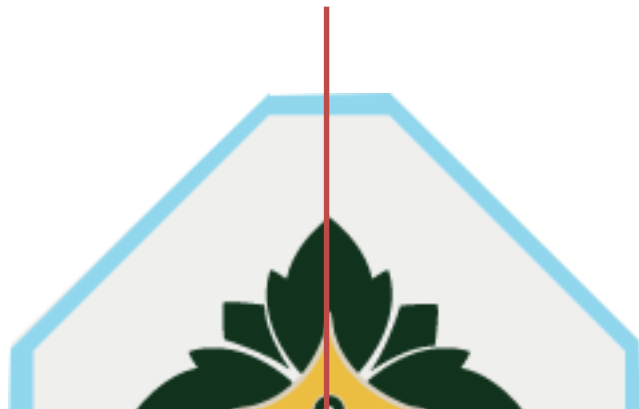
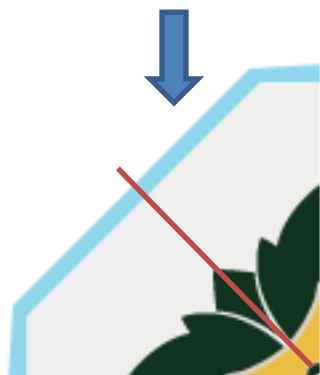

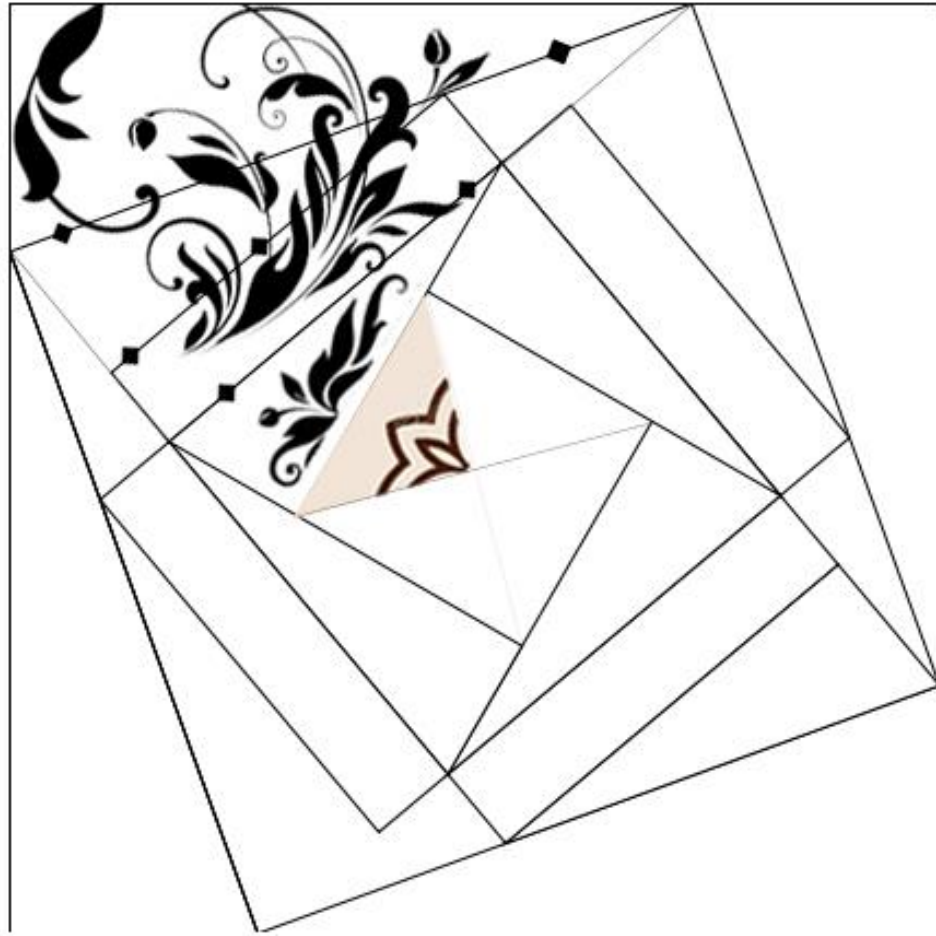



凸版

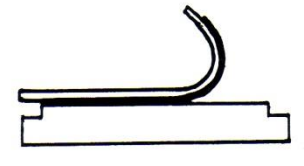
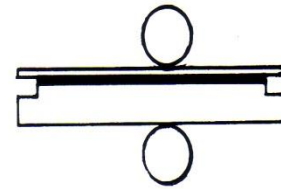
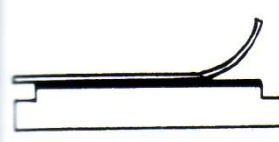
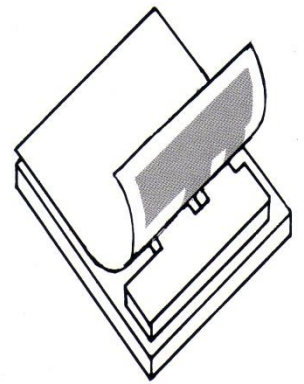
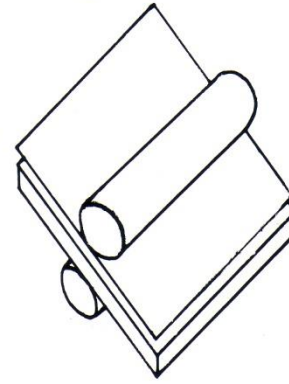
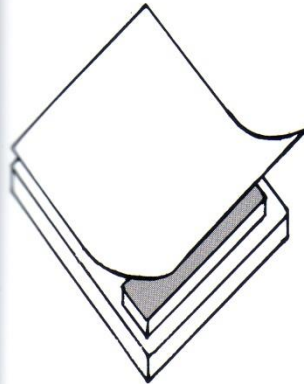
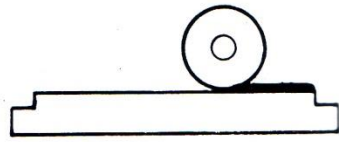
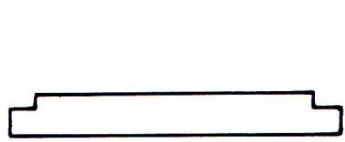
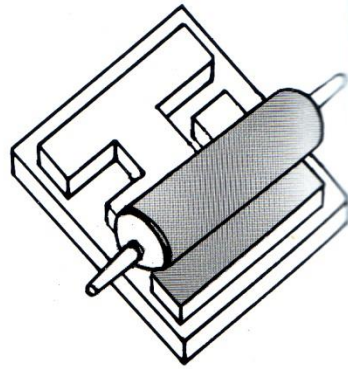
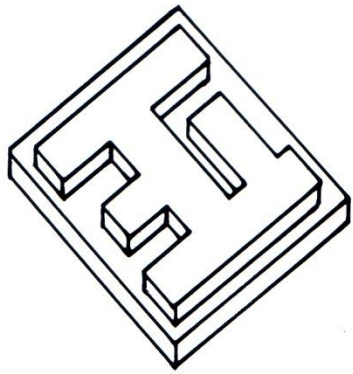

凹版

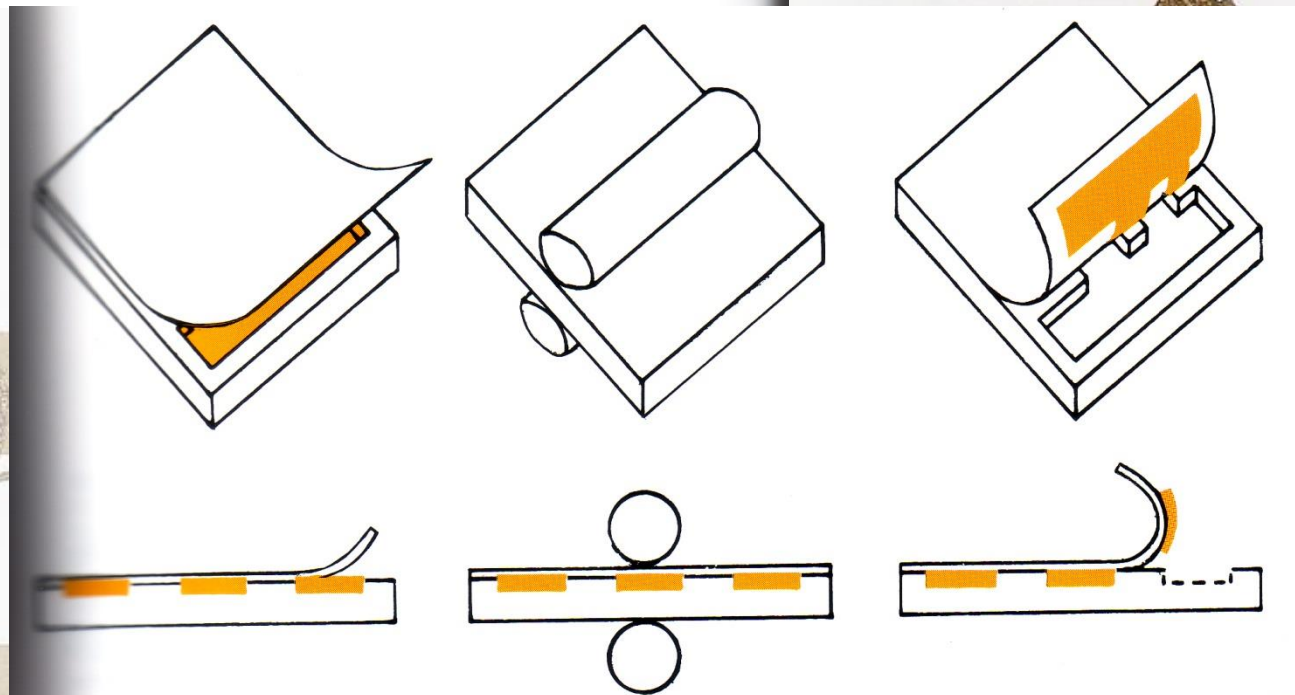
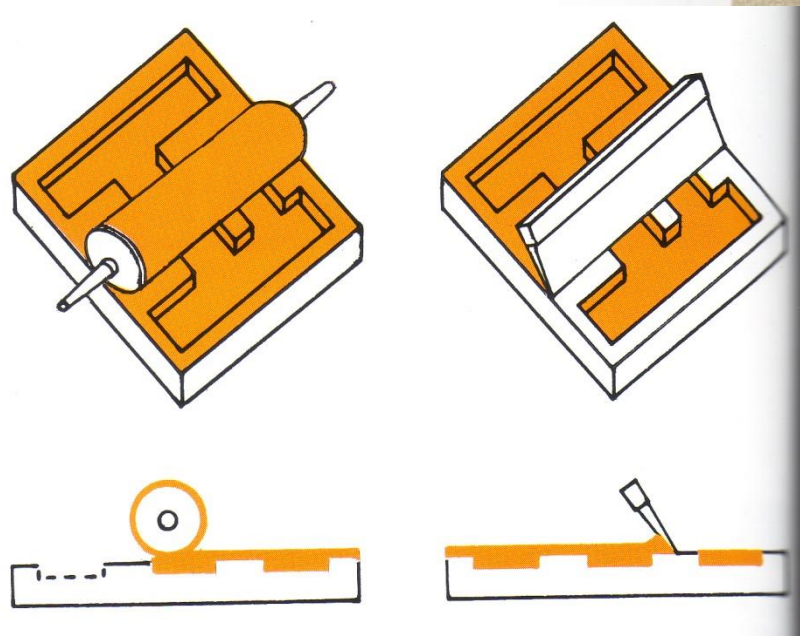

孔版

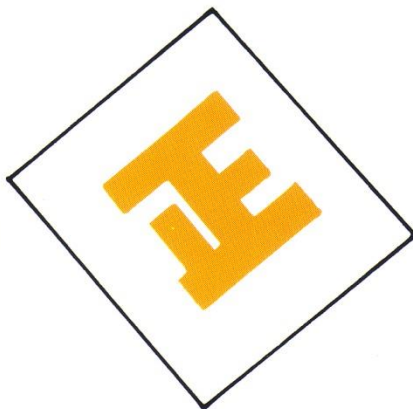
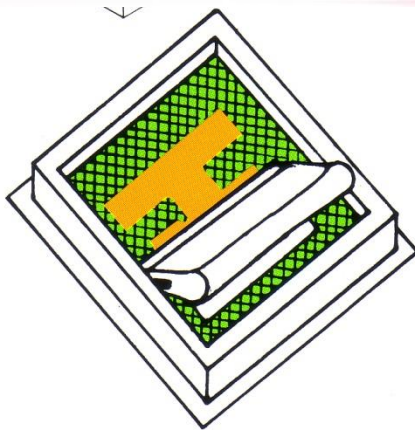
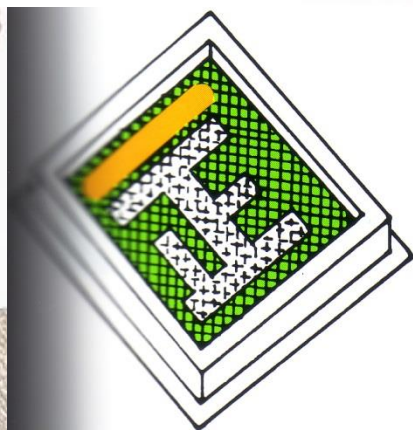
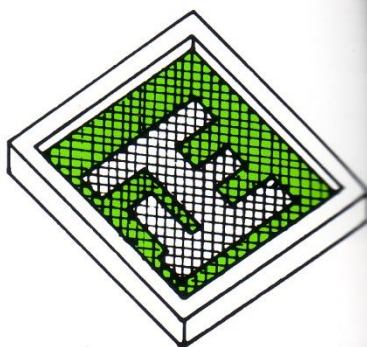
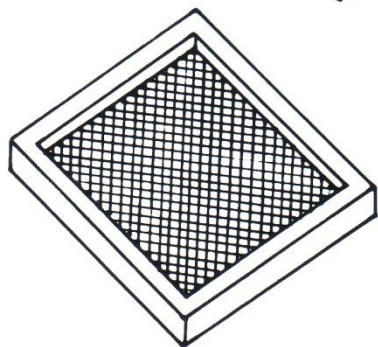



凹版不需將字左右翻轉的例外:拓印

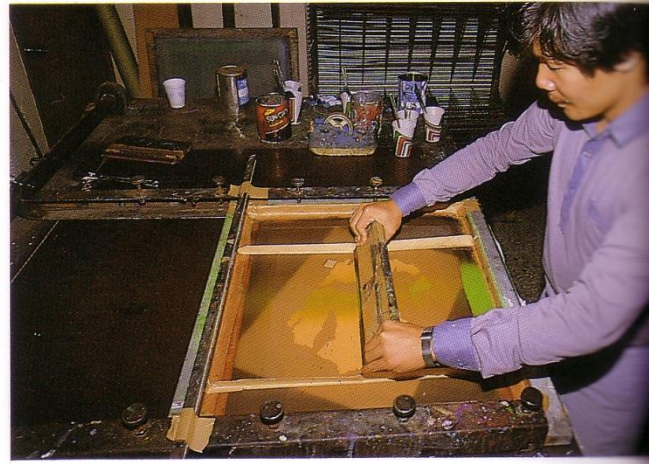
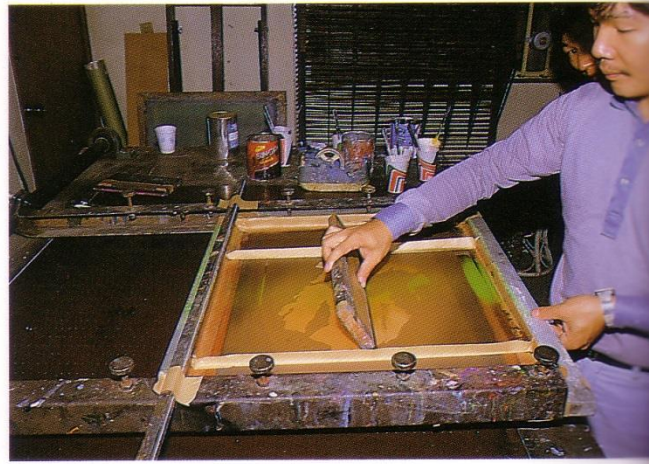
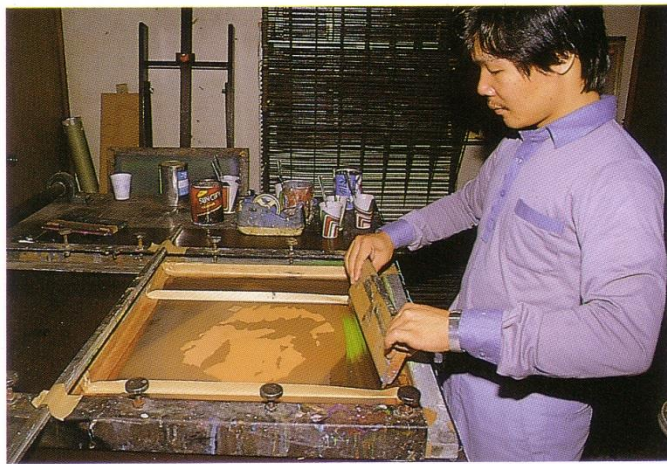
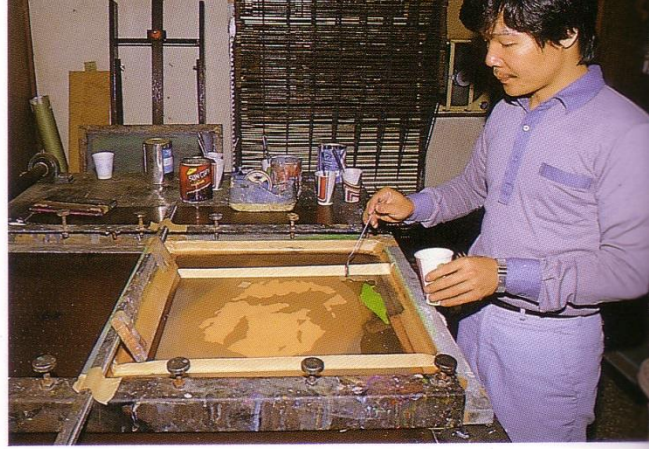





司
甲 文具有限公司

甲 文具有限公司





HCS
CUTTING

